

Rollers



**WACKER
NEUSON**
all it takes!



These reasons speak for rollers from Wacker Neuson.

1. First-class quality products – with a long service life.

You want to complete your projects perfectly – it is no question that you do not make any compromises when it comes to the quality of the machines you use. As with all solutions from Wacker Neuson, you also receive high quality products with our rollers, which will satisfy you in every aspect.

2. Large portfolio – the right solution for every application.

Whether for asphalt or soil compaction, whether a trench roller, a single drum soil compactor or a tandem roller model for application in the inner city: You have a large selection at Wacker Neuson! You will find the optimal solution for your requirements in our finely tiered product range of rollers.

3. Service network – always in the right place at the right time.

Wacker Neuson is actively at your side: with a good service network that always insists on quality and absolute reliability. In an emergency situation, we also provide on-site assistance so that you can successfully continue your work as quickly as possible.

Wacker Neuson—all it takes!

We offer products and services rendered that meet your high requirements and diverse applications. Wacker Neuson stands for reliability. This of course also applies to our comprehensive product range of rollers. We do our best every day to ensure your success. And we do this full of passion for our jobs.

Roller expertise down to the last detail.

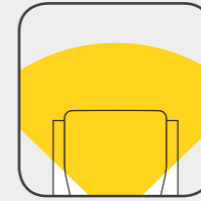

Working area in sight

The design of the rollers allows you a good view of the drum edges or the machine environment.

Read more on page 07.

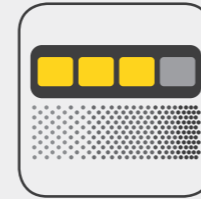

Excellent compaction performance

Regardless of which of our rollers you choose – you will be excited about the compaction performance.

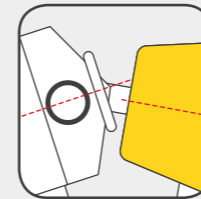

Superior stability

Whether on uneven terrain or when turning curves, the articulated joints compensate for unevenness and provide for a small turning circle. Read pages 12 and 19 to learn more details.



Finely tiered model selection

Vibratory trench rollers, tandem rollers with vibration or oscillation drums, combination rollers in different weight classes or single drum soil compactors: At Wacker Neuson, you will find exactly the unit that you need for your project.



Built-in operator comfort

All vehicles score with comfort features and plenty of freedom of movement in the operator's cab. And the remote-controlled models protect the end user from dust, exhaust fumes and noise emissions. Read more about the topic on pages 5 and 13.

All rollers in an overview.

Trench roller:



RTX-SC3

Operating weight as from 1,465 kg
> Page 04

Tandem and Combination Rollers:



RD7

731.4 kg
> Page 06



RD18-80

1,580 kg



RD18-100

1,670 kg
> Page 06



RD18-100c

1,630 kg



RD24-100

2,475 kg



RD24-100c

2,385 kg
> Page 08



RD24-100o

2,525 kg



RD28-120

2,695 kg



RD28-120c

2,595 kg
> Page 09



RD28-120o

2,755 kg



RD40-130

Operating weight as from 3,965 kg



RD40-130c

3,825 kg
> Page 10



RD40-130o

4,015 kg



RD45-140

4,345 kg
> Page 11



RD45-140c

3,995 kg



RD45-140o

4,435 kg
> Page 11

Single drum soil compactors:



RC50

4,815 kg



RC50p

4,935 kg



RC70

6,320 kg
> Page 16



RC70p

6,190 kg



RC70vo

6,105 kg

RTX-SC3

Maneuver easily, work safely: thanks to the articulated joint and the remote control operation. You always have reliable reception in trench applications, even in blind zones through cross braces.

- Maneuver easily thanks to the articulated joint
- Compaction performance from 34 kN to 68 kN
- Very high compaction performance due to the exciters, which are located below the shaft
- Thanks to the remote control, the operator is not exposed to any mechanical loads, such as hand-arm vibrations
- Protection from dust, exhaust fumes and noise emissions due to the distance to the compaction equipment
- Easy cleaning and maintenance thanks to the easily accessible machine components
- Irregularities in the engine functions are immediately discovered via the diagnostic LED display



Very good compaction results due to the cleated drums and high centrifugal force.

Compatec – the compaction control:

Compatec shows the degree of compaction of the soil. The maximum compaction is achieved once the number of displayed lights remains constant.



Change the drum width:
With the RTX-SC3, this is done in a few easy steps.



Safe and comfortable control
of the RTX-SC3 via remote control.



RTX-SC3

Performance (kN)	34.2–68.4
Weight (kg)	1,465
Type of engine	Diesel engine

Infrared remote control.

Far-reaching control:

A transmission field of up to 20 meters and an angle of 45 degrees guarantee a high level of working comfort.

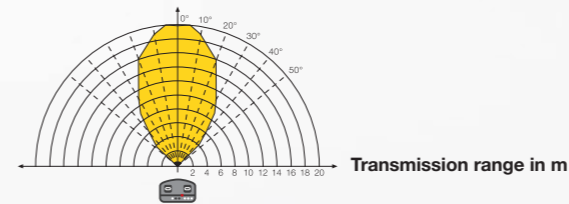

High level of safety:

It automatically stops if there is no clear line of sight between the operator and the compaction equipment.

Additional 3rd infrared contact point prevents losses of signal:

The location of the 3rd point of contact on the top side of the machine guarantees a permanent connection between the remote control and roller.

Intelligent proximity recognition sensor:

It stops automatically if a minimum safety distance between the operator and machine of less than two meters is reached.

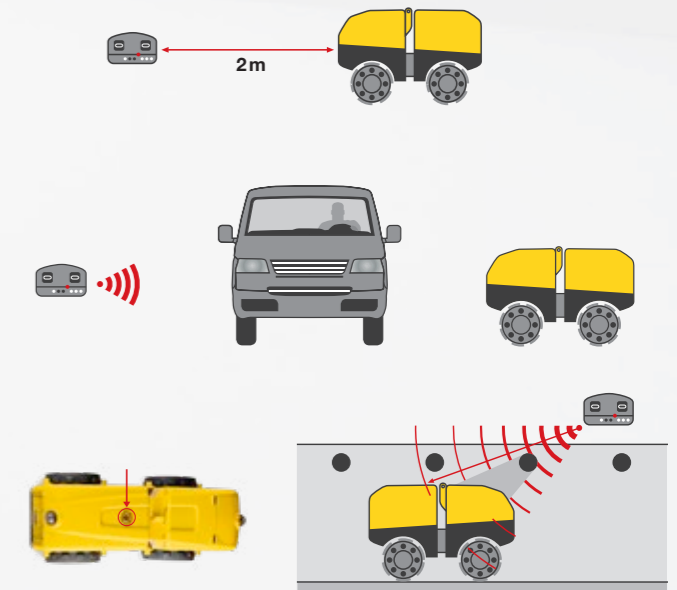

Exciters strategically placed:

Due to the exciters' low location below the central axis of the drums, the centrifugal forces are directly transferred into the ground. This way, the trench roller delivers superb compaction performance.

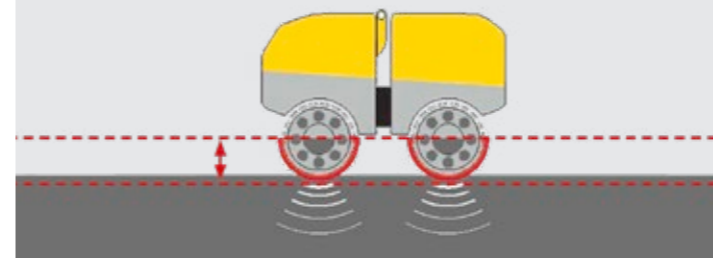

Articulated joint technology:

for easy maneuvering.

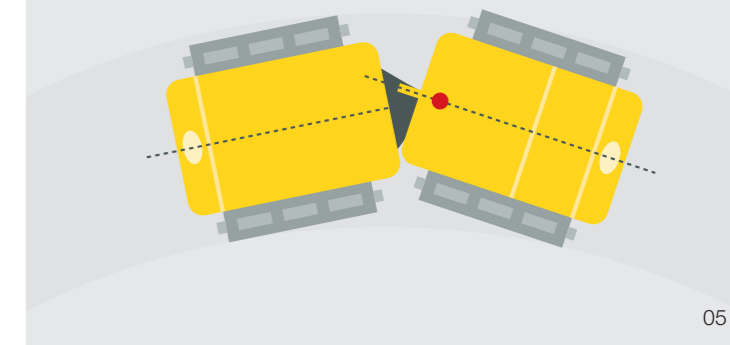

RD7

The RD7 is the right choice if you need to cover a broad range of applications. The walk-behind, dual-vibration roller optimally compacts asphalt as well as granular material. Easy access to all maintenance points without tools makes the RD7 the right partner for every construction site.

- HAV values of less than 2.5 m/s² ensure a high level of operating comfort
- The extremely low HAV values eliminate the documentation requirement
- Ergonomically shaped operator's controls directly on the guide handle reduce the physical load of the end user
- Universally deployable on soil as well as asphalt compaction



Fluid operating sequences: the long center pole and the greater leverage that results simplifies and accelerates maneuvering. This is also supported by the short distance between drums with a low center of gravity.

	RD7H	RD7HE	RD7A	RD7Ye
Operating weight (kg)	735	735	690	710
Drum width (cm)	65	65	65	65
Max. engine output (kW)	7.5	7.5	8.7	6.8

Several equipment versions.

The variable protective cage concept gives you the greatest possible flexibility. Simply choose the frame that best fits your requirements and applications.

Full engine protection –
RD7 with steel frame and engine hood



Partial engine protection –
RD7 with steel frame

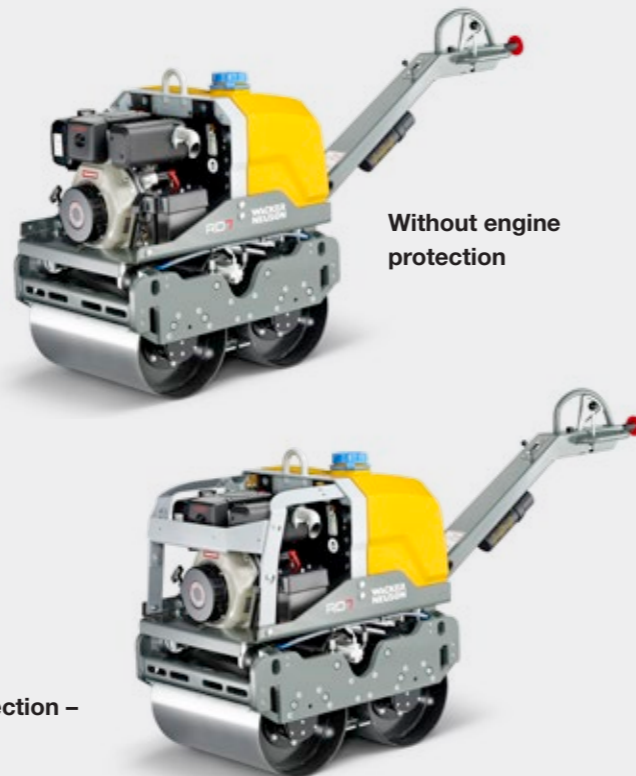

Without engine protection

RD18

Compact and extremely maneuverable – the roller RD18 is ideal for applications with limited space, e.g. in the urban sector. Due to the drum offset, you have complete curb clearance on both sides.

- Small turning radius for easy maneuvering
- Work precisely along walls thanks to the drum offset of 56 mm
- Quickly secured for transport, as the tie-downs are easy to access
- Large and perfectly balanced lifting eye for safe lifting of the roller
- Intuitive to operate via the self-explanatory display, operators can immediately begin working

Ideal for the inner city: the RD18 is the smallest ride-on asphalt roller from Wacker Neuson.



Explanation of nomenclature

c = Combination roller

	RD18-80	RD18-100	RD18-100c
Operating weight (kg)	1,580	1,670	1,630
Drum width (cm)	80	100*	100*
Engine output (kW)	16.8	16.8	16.8

* with unilateral drum support

Waisted design: for an unobstructed view of the drum edges, the machine surroundings and the construction site.



Clear sided curb clearance allows flush rolling both right or left: thanks to the offset unilateral drum support, ideal for work along walls.

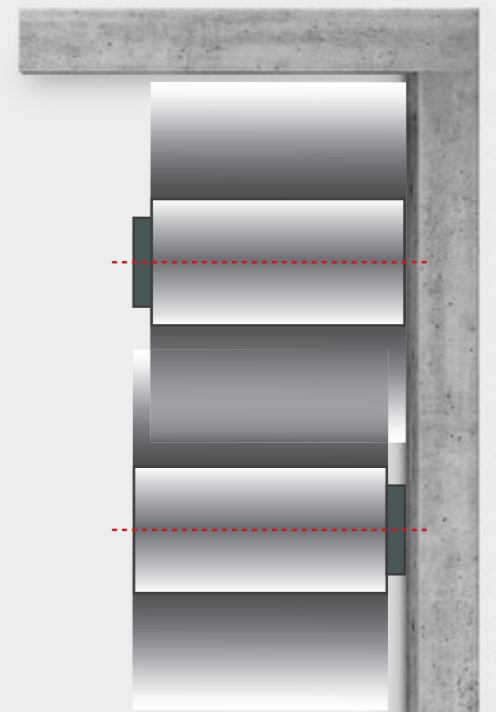

RD24, RD28

Whether a tandem, combination or oscillation roller: With the 2.5 ton machines, Wacker Neuson has a large selection – and therefore the right machine for each one of your requirements. In addition, the intuitive operation makes it easy for you to achieve perfect work results.

The central lifting point with large lifting eye is optimally balanced for safe lifting

Clearly arranged display for intuitive operation

Headlights and rotating beacon standard, working lights optional

Pleasant work thanks to the large legroom and moving seat

Standard ROPS (Roll Over Protective Structure) can be folded back for transport

The compact design with low operator's station allows for a very good view of the drums

Good maneuverability and optimal travel stability – with simultaneously very good compaction performance, all made possible by the articulated pendulum joint.

Compact asphalt surfaces without the formation of undulations: due to the large drum diameter and the low center of gravity.

Variable vibration: the frequency can be adjusted via the engine speed

Two vibration levels for optimal adjustment to the material to be compacted

Vibration-isolated operator's cab for comfortable work

Drum offset of 50 mm can also be converted to a linear arrangement if required

	RD24-100	RD24-100c	RD24-100o
Operating weight with roll-over protective structure (kg)	2,475	2,385	2,525
Drum width (cm)	100	100	100
Engine output (kW)	24	24	24

Explanation of nomenclature

- o = Oscillation roller
- c = Combination roller

	RD28-120	RD28-120c	RD28-120o
Operating weight with roll-over protective structure (kg)	2,695	2,595	2,755
Drum width (cm)	120	120	120
Engine output (kW)	24	24	24



Oscillation for perfect seams between existing and new asphalt.



Optimal view due to the laterally adjustable seat.

RD40, RD45

The rollers of the 4-ton class from Wacker Neuson take care of work particularly efficiently: Due to their high compaction force, the wide drums as well as the choice of two vibration levels and two amplitudes, they provide the optimal performance for all requirements. These models are available as tandem roller, tandem roller with oscillation drum or combination roller.

Self-explanatory display for intuitive operation: get going immediately without a familiarization period.

Ergonomic operator's platform with laterally displaceable seat

Balanced weight distribution on the front and rear drum for uniform compaction results.



Three-point articulated pendulum joint compensates for unevenness, attenuates impacts, and the drum lies on any surface in the best possible way

Self-cleaning water filter and central water outlet for the entire machine

	RD45-140	RD45-140c	RD45-140o
Operating weight with roll-over protective structure (kg)	4,345	3,995	4,435
Drum width (cm)	138	138	138
Engine output (kW)	37.4	37.4	37.4

Large drum diameter minimizes the formation of cracks or waves and accomplishes good compaction results.

Easy radiator cleaning due to separately removable flap on the engine hood.



Central drainage with just one touch.



	RD40-130	RD40-130c	RD40-130o
Operating weight with roll-over protective structure (kg)	3,965	3,825	4,015
Drum width (cm)	130	130	130
Engine output (kW)	37.4	37.4	37.4

Explanation of nomenclature

o = Oscillation roller c = Combination roller

The advantages of the tandem and combination rollers in detail.

From the technical outfitting for the actual compaction work to the comfort features to the practical details for transport or maintenance: Here you can see what all models have in common.

Three-point articulated pendulum joint.

Uniform compaction and a high level of travel stability are the key advantages of the three-point articulated pendulum joint with which all tandem and combination rollers are equipped, except for the RD7. This leads to a uniform pressure distribution on the tires or the drums, in particular when turning curves. In addition, it improves maneuverability and provides for maximum tipping safety and stability, even on uneven site conditions, e.g. coarse gravel.

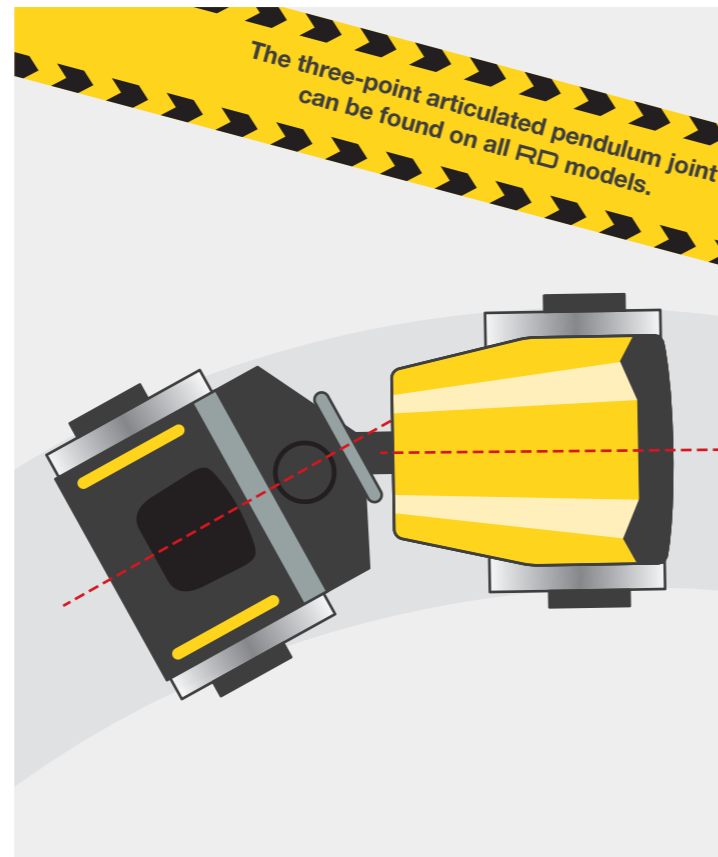
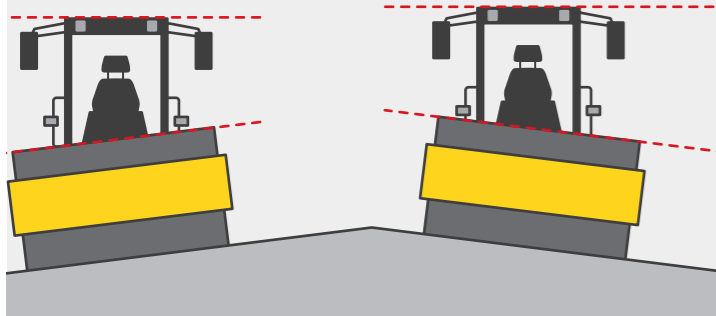

Clearly arranged display.

Self-explanatory, intuitive to operate and clearly structured: The display of the rollers from Wacker Neuson is very user-friendly. This way, operators can manage everything starting from the first moment – an important aspect for rental yards in particular.

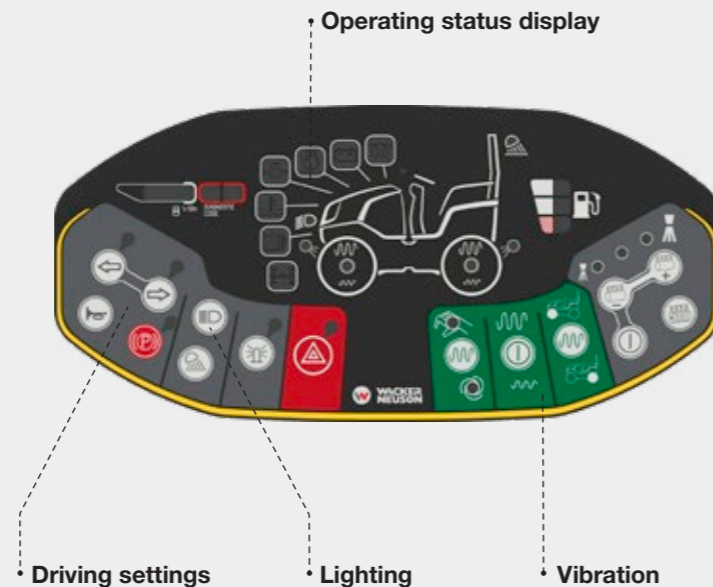

High level of comfort for the operator.

All rollers are equipped as standard with a completely vibration-insulated operator's cab. In this way, the operator is optimally protected against vibrations. Additional safety is provided by steps for convenient entry, plenty of legroom and an operator's seat that can be individually adapted to weight and height.



The best lighting.

Whether for work at dusk, at night or when cloudy: The rollers from Wacker Neuson provide sufficient light. Optional working lights can be attached to the ROPS bar for the tandem and combination models. Already included in the standard scope: a rotating beacon which permits the roller on public roads.



Standard fold-down ROPS (Roll Over Protective Structure).

The ROPS bar provides added safety. It can be folded to the rear as a standard. The roller achieves very compact transport dimensions in this way.



Simple maintenance.

All rollers are designed so that maintenance is taken care of with a few movements: This includes good access to the entire engine compartment as well as easy exchange of the air cleaner. This saves time and money.

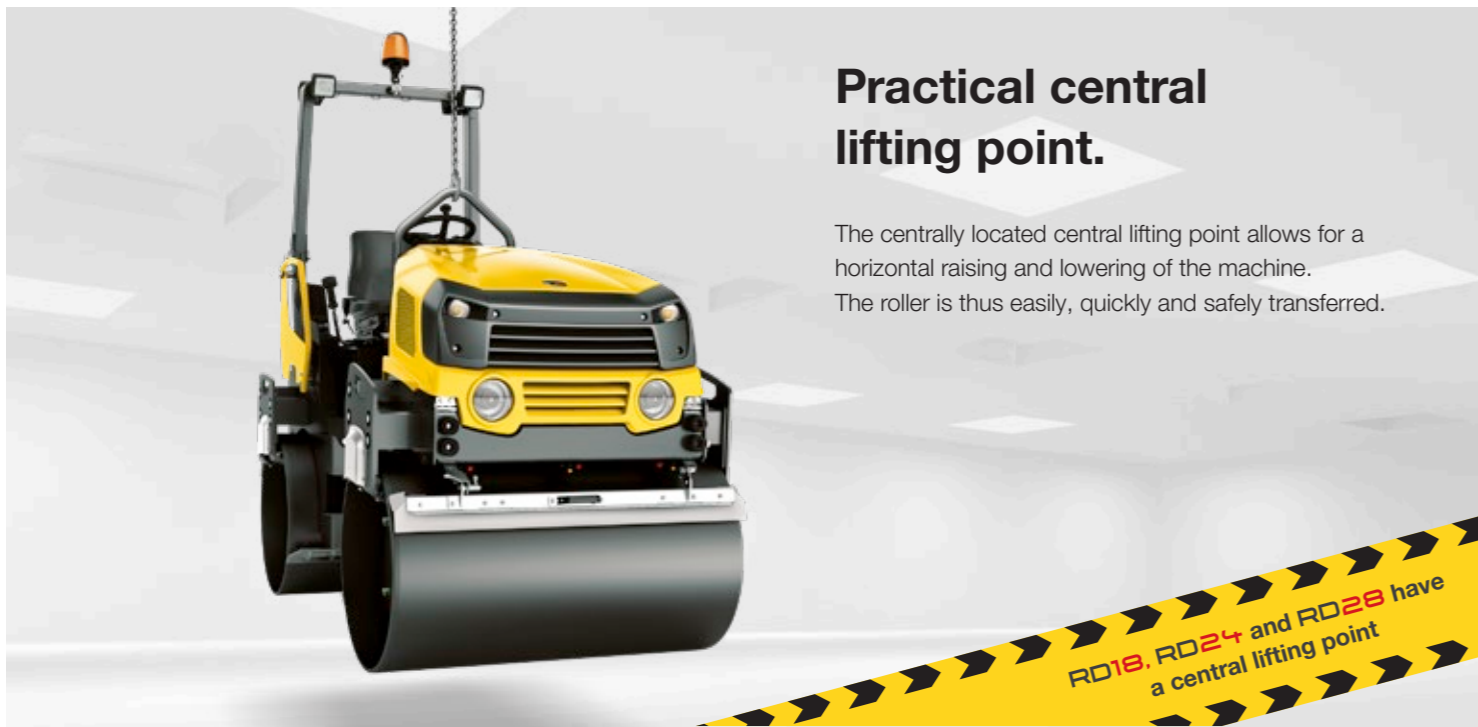

Practical central lifting point.

The centrally located central lifting point allows for a horizontal raising and lowering of the machine. The roller is thus easily, quickly and safely transferred.

RD18, RD24 and RD28 have a central lifting point

Tandem roller:

Front and rear with vibration drums.

The vibration drum optimally brings the material to be compacted into oscillation with quick successive vertical forces. The built-in eccentric weight provides for a fast rotation and you achieve excellent compaction performance.

Ideal for:
All classic compaction work

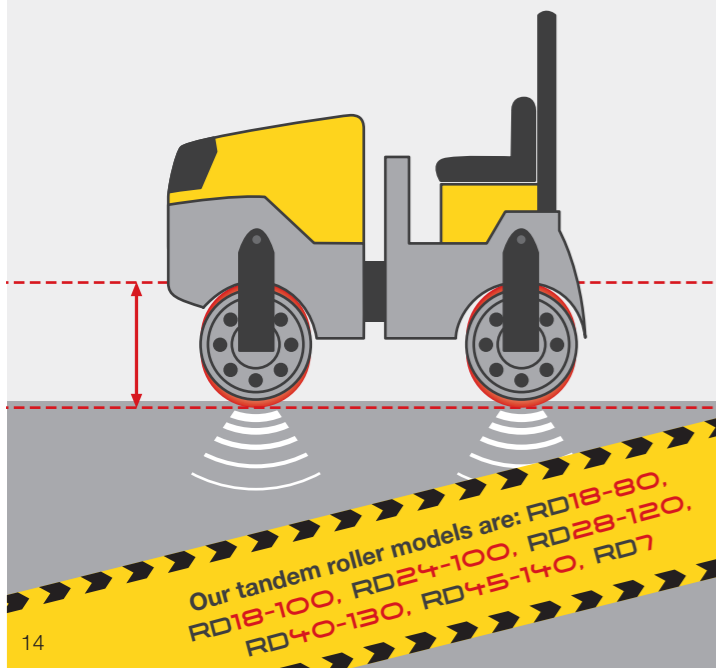

Our tandem roller models are: RD18-80, RD18-100, RD24-100, RD28-120, RD40-130, RD45-140, RD7

Combination roller:

Vibration drum in the front, tires in the rear.

The combination roller is equipped with only one vibration drum. The rear axle consists of rubber tires for pressing on the asphalt. This creates particularly high quality and smooth surfaces.

Ideal for:
Asphalt compaction on sidewalks and bicycle tracks



Our combination roller models are: RD18-100c, RD24-100c, RD28-120c, RD40-130c, RD45-140c

Oscillation roller:

Vibration drum in the front, oscillation drum in the rear.

The oscillating movement is caused by a quickly changing forwards-reverse rotary movement of two masses in the drum.

These forces are continuously directed into the ground in a targeted manner. At the same time, the vibration exposure is significantly lower than with a vibration drum. This also has a positive effect on the service life as well as the driving comfort of the machine.

Ideal for:
Compaction work in the inner city, near vibration-sensitive structures (e.g. bridges, residential buildings, historic buildings), on seams (hot on cold) and for minor repair work

Operating mode 1:
Static in the front, oscillation in the rear

Operating mode 2:
Vibration in the front, static in the rear

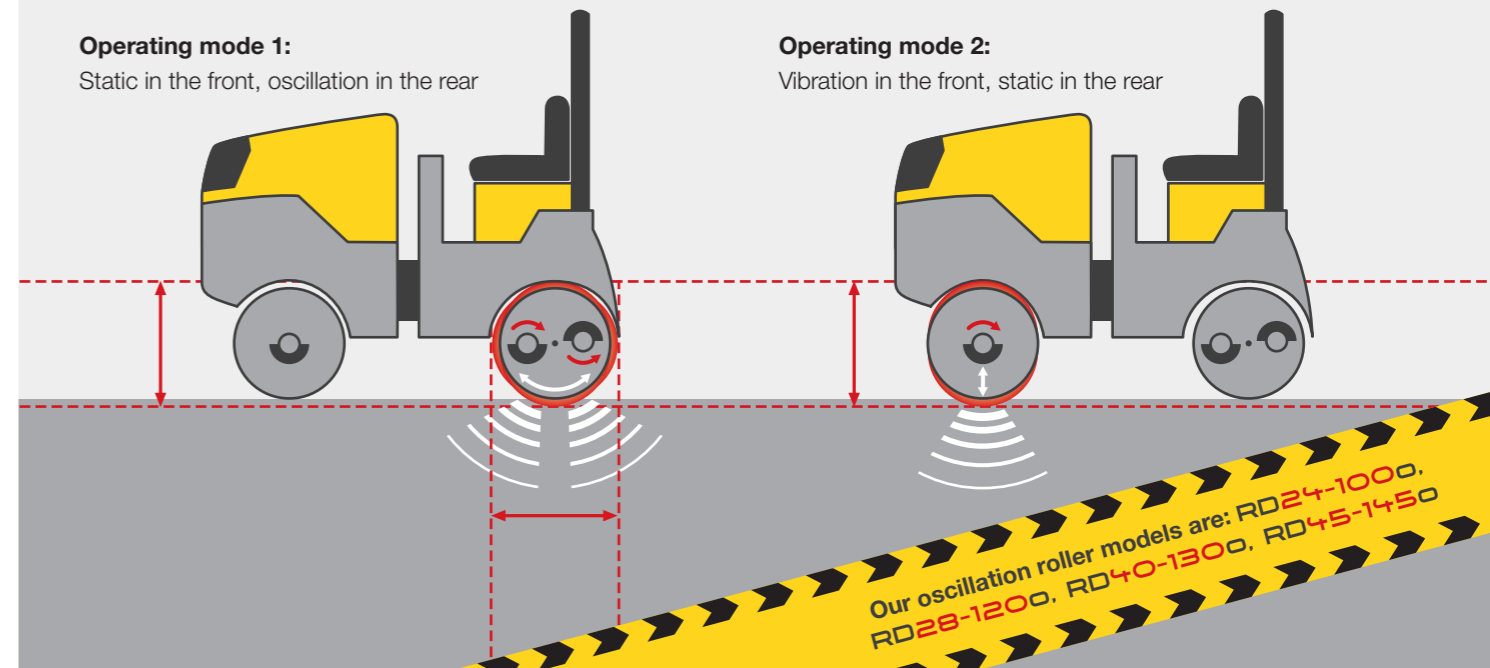

Our oscillation roller models are: RD24-100o, RD28-120o, RD40-130o, RD45-145o

Larger time frame, higher surface capacity:

With oscillation, you can compact asphalt at lower material temperatures as well. Compared to compaction with vibration you thus have a larger time frame.

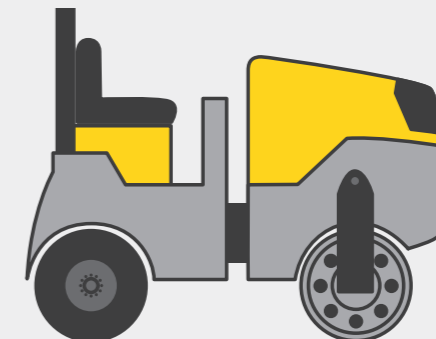

More time and flexibility

20% greater temperature range



RC50, RC70

The single drum soil compactors of the 5- and 7-ton class are ideal when it comes to quick compaction of large areas and gradeability. In rough terrain conditions, they also prove themselves through their stable driving position and a large slope angle.

	RC50	RC50p
Operating weight with roll-over protective structure (kg)	4,815	4,935
Drum width (cm)	137	137
Engine output (kW)	55.4	55.4
Type of drum	Smooth drum* cleated	

	RC70	RC70p	RC70vo
Operating weight with roll-over protective structure (kg)	6,320	6,190	6,105
Drum width (cm)	168	168	168
Engine output (kW)	55.4	55.4	55.4
Type of drum	Smooth drum	cleated	Smooth drum

Numerous options, e.g. air-conditioning system, various seat designs, lighting versions, compaction control

Spacious operator's platform with plenty of legroom, a high level of ergonomics and a very good view for fatigue-free work.



Quick and easy to maintain, since all of the maintenance points are on one side

Pendulum support in the joint protects the operator by damping the operator's platform

Available with cabin, canopy or ROPS (Roll Over Protective Structure)

Good all-round visibility thanks to the compact dimensions and high seat position



Optionally with oscillation compaction in vibration-sensitive areas such as on bridges.

Three-point articulated pendulum joint for even weight distribution and compaction, even when turning a curve and in uneven terrain conditions!

Explanation of nomenclature

- vo = Vibration or oscillation adjustable
- c = Combination roller
- p = Roller with cleated drum

Get started with the work quickly: self-explanatory display and joystick are intuitive to operate.



Safe working:

good 360° visibility from the operator's seat – also of the drum and wheels.

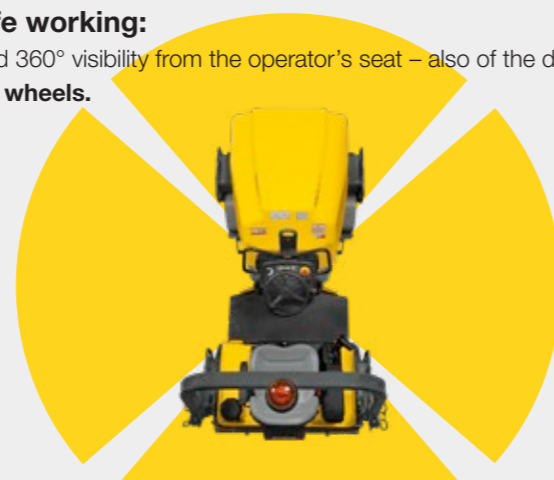

Master up to a 60% gradient:

thanks to the powerful wheel drive.

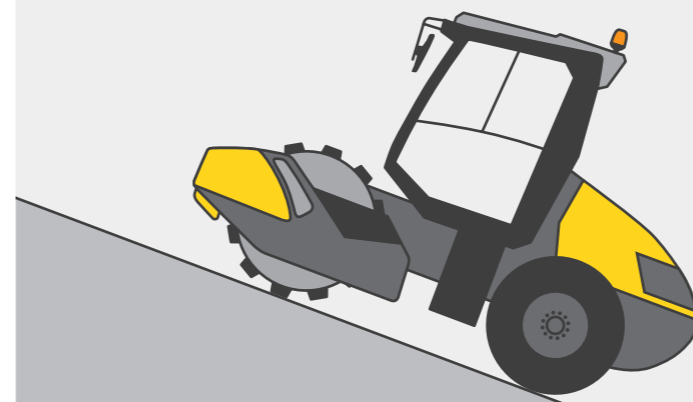

Comfort for the operator: the seat and steering column can be individually adjusted.



The advantages of the tandem and combination rollers in detail.

With the five compact tandem and combination drum rollers, we have the right solution for you for various gradients, requirements and spatial conditions. In addition, the operator's cab can be outfitted to meet your individual needs.

Smooth drum.

Due to the low depth effect, the smooth drum is ideal for applications in sensitive areas, e.g. near vibration-sensitive structures like historic buildings or on surfaces under which tubes and utility lines run. In addition, smooth drums are ideal for:

- Non-cohesive or weakly cohesive soils, such as sand and gravel
- Surfaces that have already been processed with a cleated (sheepsfoot) drum roller

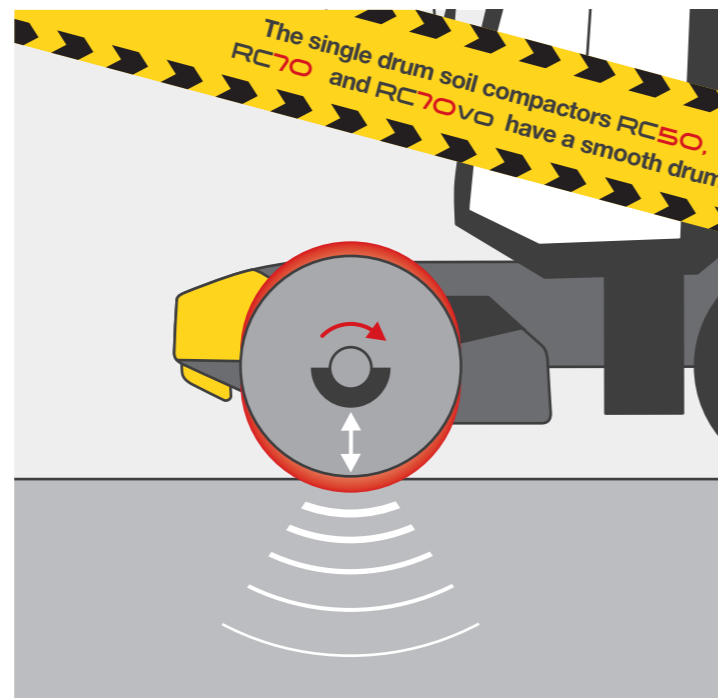

Cleated (sheepsfoot) drum.

The trapezoid-shaped pads of a cleated drum compact the ground through kneading and crushing. The further the compaction progress, the less the pads sink into the ground. The application areas of cleated drums are:

- Fine-grained soils with a high water content, incorporation of binding materials, such as lime or cement, into acidic soils
- Compaction of cohesive, less supportive moist ground, as well as friable soft stone (e.g. when building dams)

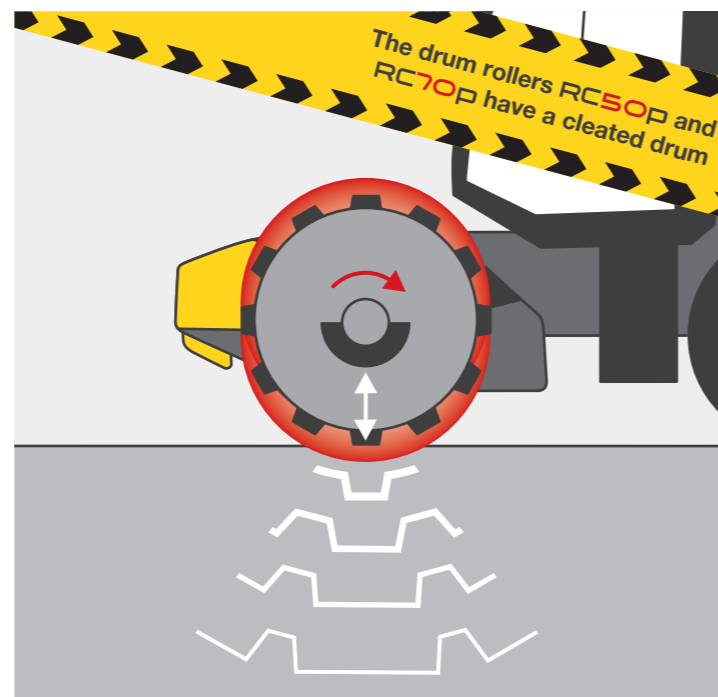

One single drum soil compactor, two types of compaction.

All tandem and combination drum rollers compact through vibration, but the RC70vo offers you a special extra: You can use it to choose between the vibration and oscillation operating modes.

Type of compaction 1:

Vibration for high compaction depth.

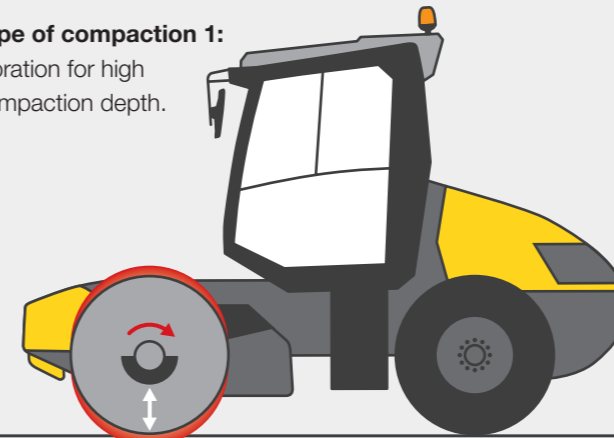

Type of compaction 2:

Oscillation for optimal surface compaction.

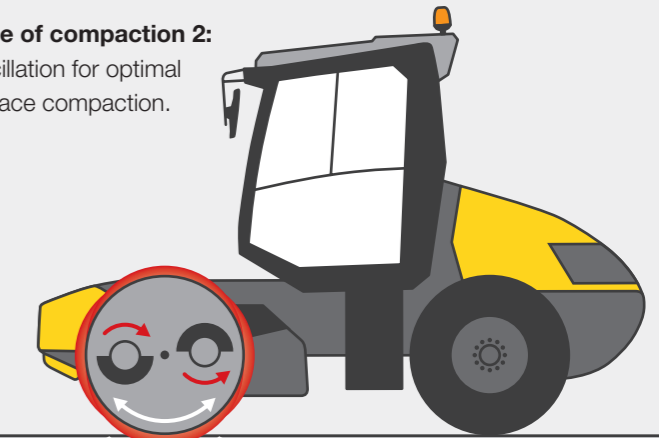

Three-point articulated pendulum joint.

The tandem and combination drum rollers are also equipped with a three-point articulated pendulum joint. It evenly distributes the weight on the drums and wheels. In addition, it also minimizes the tipping danger at a full steering angle and provides for consistently good compaction results.

In uneven terrain, the low center of gravity of the tandem and combination drum rollers provides for stable straight-ahead travel and safe maneuvering. The pendulum support in the joint protects the operator by damping the driver's cabin.

Uneven ground conditions, quiet cabin:

The pendulum support has a damping effect.

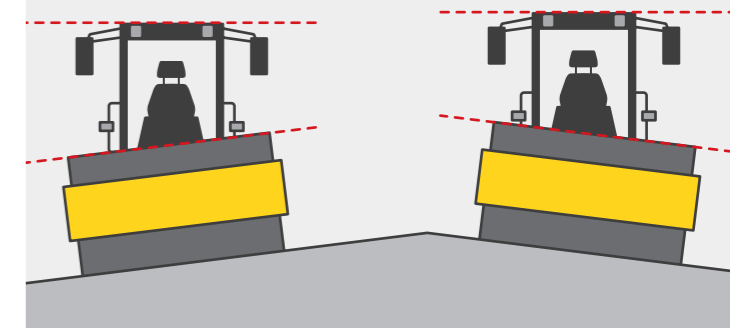

Tip-safe in curves:

Thrusting force distribution always in the green range.

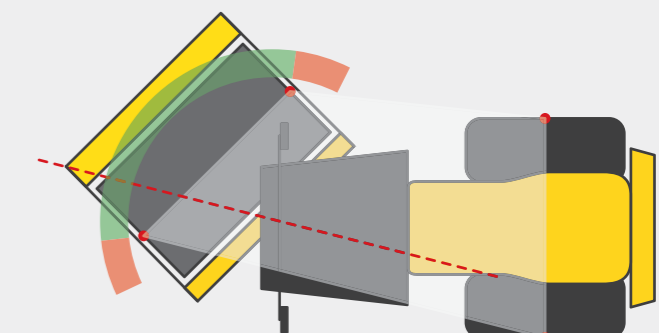

Technical data (trench, combination and tandem rollers)

TRENCH, TANDEM AND COMBINATION ROLLERS

		RTX-SC3	RD7H	RD7He	RD7A	RD7Ye	RD18-80	RD18-100	RD18-100c	RD24-100	RD24-100c	RD24-100o	RD28-120	RD28-120c	RD28-120o	RD40-130	RD40-130c	RD40-130o	RD45-140	RD45-140c	RD45-140o	
UNIT																						
Max. operating weight	kg	1,465	735	735	690	710	1,840	1,950	1,830	3,190	3,110	3,240	3,410	3,320	3,470	4,920	4,790	5,230	5,300	4,960	5,640	
Operating weight with roll over protection system	kg	-	-	-	-	-	1,580	1,670	1,630	2,475	2,385	2,525	2,695	2,595	2,755	3,965	3,825	4,015	4,345	3,995	4,435	
Max. operating width	mm	820	650	650	650	650	856	1,056	1,000	1,050	1,050	1,050	1,250	1,220	1,250	1,350	1,338	1,350	1,430	1,380	1,430	
Side overhang (left/right)	mm	-	30	30	30	30	-	-	-	55/55	55/55	55/55	55/55	55/55	55/55	63/63	63/63	63/63	63/63	63/63	63/63	
Turning radius (inside)	mm	1,600	-	-	-	-	2,230	2,130	2,130	2,470	2,470	2,470	2,370	2,370	2,370	2,690	2,690	2,690	2,650	2,650	2,650	
Drum type in front	-	cleated	smooth/undivided	smooth/undivided	smooth/undivided	smooth/undivided	smooth/undivided	smooth/undivided	smooth/undivided	smooth/undivided	smooth/undivided	smooth/undivided	smooth/undivided	smooth/undivided	smooth/undivided	smooth/undivided	smooth/undivided	smooth/undivided	smooth/undivided	smooth/undivided	smooth/undivided	smooth/undivided
Drum type in rear	-	cleated	smooth/undivided	smooth/undivided	smooth/undivided	smooth/undivided	smooth/undivided	smooth/undivided	-	smooth/undivided	-	smooth/undivided	smooth/undivided	-	smooth/undivided	smooth/undivided	-	smooth/undivided	smooth/undivided	-	smooth/undivided	smooth/undivided
Tire size in rear	-	-	-	-	-	-	-	-	-	-	205/60-R15	-	-	9.5/65-15	-	-	-	-	-	10.5/80-16	-	
Drive system	-	Kohler KDW 1.003	One cylinder, 4-stroke, air-cooled, diesel engine, Hatz engine		Honda gasoline engine air-cooled, single-cylinder, 4-stroke engine	Vertical cylinder, 4-stroke, air-cooled, diesel engine, Yanmar engine	Kubota diesel engine D1005			Kubota diesel engine D1503, with diesel particulate filter						Kubota diesel engine V2203, with diesel particulate filter						
Output	kW	14.8	7.5	7.5	8.7	6.8	16.8	16.8	16.8	24	24	24	24	24	24	37.4	37.4	37.4	37.4	37.4	37.4	37.4
Fuel tank capacity	l	24	5.4	5.4	5.4	5.4	33	33	33	42	42	42	42	42	42	73	73	73	73	73	73	73
Speed	km/h	2.5	4.5	4.5	4.5	4.5	0-11	0-11	0-11	0-12	0-12	0-12	0-12	0-12	0-12	0-11	0-11	0-11	0-11	0-11	0-11	0-11
Gradeability with/without vibration	%	45/50	26	26	26	26	30/40	30/40	30/40	30/40	30/40	35/40	30/40	30/40	35/40	30/40	30/40	30/40	30/40	30/40	30/40	30/40
Centrifugal force front I/II	kN	68.4	22.5	22.5	22.5	22.5	25/16	25/16	25/16	46/28	46/28	46/28	52/32	52/32	52/32	64/39	64/39	64/39	64/39	64/39	64/39	64/39
Centrifugal force rear I/II	kN	68.4	22.5	22.5	22.5	22.5	25/16	25/16	-	46/28	-	-	52/32	-	-	-	-	-	64/39	-	-	
Water tank capacity	l	-	60	60	60	60	70	70	70	180	180	180	180	180	180	285	285	285	285	285	285	285

Outfitting and options (selection)

TANDEM AND COMBINATION ROLLERS

	RD18	RD24	RD28	RD40	RD45
CE conformity	●	●	●	●	●
Warning signs, DIN/ISO	●	●	●	●	●
Scraper bar, fold-down	●	●	●	●	●
Roll-over protective structure, fold-down	●	●	●	●	●
Black artificial leather operator's seat	●	●	●	●	●
Engine stop automatics	●	●	●	●	●
Trailer hitch	-	○	○	○	○
Hydraulic oil, standard	●	●	●	●	●
Hydraulic oil, biodegradable	○	○	○	○	○
Belt guard	●	●	●	●	●
Antifreeze injection	○	○	○	○	○
Edge pressing and cutting equip. front right	-	○	○	○	○
Cutting wheel, diameter of 350 mm	-	○	○	○	○
Drum edge lighting, LED	-	○	○	○	○
Pressure roll 45 degrees, 5 cm layer	-	○	○	○	○
Pressure roll 60 degrees, 5 cm layer	-	○	○	○	○
Track indicator	-	○	○	○	○

● Standard ○ Option - not available

TANDEM AND COMBINATION ROLLERS

	RD18	RD24	RD28	RD40	RD45
Water sprinkling for edge pressing and cutting machine	-	○	○	-	-
Complete crushed stone spreader, precision roller spreader	-	○	○	○	○
Reverse operation alarm, volume-regulating	●	●	●	●	●
Lighting StVZO [Road Traffic Licensing Regulations]	●	●	●	●	●
Work lighting on roll over protection system, 4-fold, LED	○	-	-	-	-
Work lighting on roll over protection system, 4-times, halogen	-	○	○	○	○
Rotating beacon on roll over protection system	●	●	●	●	●
Acoustic insulation (proofing)	○	○	○	○	○
Flow divider	-	○	○	○	○
Industrial Supervisory Board final acceptance	○	○	○	○	○

TRENCH ROLLER

	RTX-SC3
Smooth drums	○
Long scraper bar	○
Short scraper bar	●

Explanation of nomenclature

- = Oscillation roller
- ◻ = Combination roller

Technical data (single drum soil compactors)

		RC50	RC50p	RC70	RC70p	RC70vo
		UNIT				
Max. operating weight	kg	5,710	5,530	7,580	6,920	6,380
Operating weight with roll over protection system	kg	4,815	4,935	6,320	6,190	6,105
Max. operating width	mm	1,370	1,370	1,680	1,680	1,680
Side overhang left/right	mm	65/65	65/65	80/70	80/70	80/70
Turning radius (inside)	mm	3,375	3,375	3,310	3,310	3,310
Type of drum	-	smooth/undivided	cleated	smooth/undivided	cleated	smooth/undivided
Tire size in rear	-	TR 12.4-24 8 PR	TR 12.4-24 8 PR	AW 14.9-24 8 TL	TR 14.9-24 8 TL	AW 14.9-24 8 TL
Drive system	-	Kubota diesel engine V3307-CR-T				
Output (ISO 14396)	kW	55.4	55.4	55.4	55.4	55.4
Fuel tank capacity	l	123	123	123	123	123
Infinitely variable speed	km/h	0-12.5	0-12.5	0-12.5	0-12.5	0-12.5
Gradeability with/without vibration	%	55/60	55/60	55/60	55/60	55/60
Centrifugal force in front I/II	kN	69	69	125/95	125	123

Outfitting and options (selection)

		RC50	RC50p	RC70	RC70p	RC70vo
Paint 1 RAL color + gray		○	○	○	○	○
Rigid steering column		●	●	●	●	●
Tilttable steering column		○	○	○	○	○
Diamond tread tire set		●	○	●	○	●
Set of tires with tractor tread		○	●	○	●	○
CE conformity		●	●	●	●	●
Warning signs, DIN/ISO		●	●	●	●	●
Scraper bar		○	●	○	●	○
Rigid roll over protection system, with canopy		●	●	●	●	●
Roll over protection system cab with heater, FOPS tested (Level I), 1 access door		○	○	○	○	○
Air-conditioning system		○	○	○	○	○

● Standard ○ Option - not available

All information relates to the base machine. Subject to changes.

The product range of Wacker Neuson includes over 300 different product groups with different versions. The product data may vary accordingly with the selection of different options. The Wacker Neuson products shown are examples and as such are subject to regular changes. We are happy to make you a specific offer upon request!

Reproduction only with the written approval of Wacker Neuson.

© Wacker Neuson SE

Configuration options

		RC50	RC50p	RC70	RC70p	RC70vo
Standard forward + reverse travel lever		●	●	●	●	●
Forward + reverse travel lever with selection of dozer blade		○	○	○	○	○
Black artificial leather operator's seat		●	●	●	●	●
Black artificial leather operator's seat, comfort outfitting		○	○	○	○	○
Right/left seat adjustment		○	○	○	○	○
Hydraulic oil, standard		●	●	●	●	●
Hydraulic oil, biodegradable		○	○	○	○	○
Radio		○	○	○	○	○
Rigid roll over protection system		○	○	○	○	○
Synthetic material canopy with integrated FOPS (Level I)		○ ¹	○ ¹	○ ¹	○ ¹	○ ¹
Dozer blade		○	○	○	○	-
Two-part cleated shells, not mounted		○	-	○	-	-
Spare tire set with tractor tread		○	○	○	○	○
Spare tire set, all-weather		○	○	○	○	○
Earthworks compaction control		○	○	○	○	○
Speedometer		○	○	○	○	○
Engine stop automatics		○	○	○	○	○
Vibration frequency display		○	○	○	○	○
Rear-view camera		○ ²	○ ²	○ ²	○ ²	○ ²
Reverse operation alarm, volume-regulating		●	●	●	●	●
Vibration automatic		○	○	○	○	○
Lighting StVZO [Road Traffic Licensing Regulations]		● ³	● ³	● ³	● ³	● ³
Work lighting, 4-fold, halogen		○	○	○	○	○
Work lighting, 4-fold, LED		○	○	○	○	○
Rotating beacon		●	●	●	●	●
Battery disconnect switch, electronic		○	○	○	○	○
Industrial Supervisory Board final acceptance		○	-	○	-	○

● Standard ○ Optional - not available ¹ Only available with selection "Rigid roll over protection system" ² "Rigid roll over protection system"

³ Mandatory with selection "Industrial Supervisory Board final acceptance"

Explanation of nomenclature

vo = Vibration or oscillation adjustable

p = Roller with cleated drum

Your everyday work day is full of challenges. We have the right solutions and help you to be ahead of the competition.

We offer you everything you need for this purpose: **Wacker Neuson—all it takes!**

Products



Concrete technology



Compaction

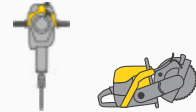

Demolition technology



Excavators



Wheel loaders



Telehandlers



Dumpers



Generators

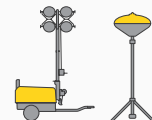

Lighting



Pumps



Used equipment

www.wackerneuson.com

Services



Financial solutions

Uncomplicated, transparent and individual financing options for you.



Repair & maintenance

Excellent and fast maintenance. Repairs with original spare parts.



Academy

We expand your know-how: practice-oriented and within an ideal learning environment.



EquipCare

Everything about the machines at a glance, via app or PC – EquipCare.



Rental

Protect your liquidity and rent top-maintained construction equipment as needed.



Concrete specialists

Our specialists advise you in all project stages.



E-Store

Buy original spare parts online conveniently – for all Wacker Neuson product groups.



Spare parts

Every minute counts:

Within the shortest period of time, we deliver over 150,000 genuine Wacker Neuson spare parts to your construction site.



WN.EMEA.10098.V05.EN-US

03/2021 EN



Facebook
wackerneuson



Instagram
@wackerneuson



Youtube
Wacker Neuson



LinkedIn
Wacker Neuson Group